

Leader don't follow steps  
... marks the way

## WHAT IS THE CLASSIC BARRIER B-110?

Safety traffic barrier are refillable, also specially resistant to impacts and harsh weathering so are very durables.

Its main function is to avoid the vehicles pass to forbidden or restricted areas, are useful as traffic security delimitter.

Its suggested use is forming rows or curves depending on your needs and contributing always for a better safety environment.



## FEATURES

- Very useful as a limiter, signaliser and safety provider on road and construction works.
- Made out in high molecular density polyethylene,
- Manufactured out in one solid piece means durability.
- Modular and lightweight are easy handle and transport.
- Resistance to weathering including UV rays protection.
- Uniformity in internal walls thickness traduces in a better performing on normal daily hard use.
- Rounded ends and no sharpen edges to avoid any harm.
- The superior cap on top permits to charge water for ballast directly from the tank truck hose.
- The coupling system (male-female) for bond are very easy to handle and allow to construct little straihn lines or large curves.
- Has a bridge on bottom for water pass in case of rain.

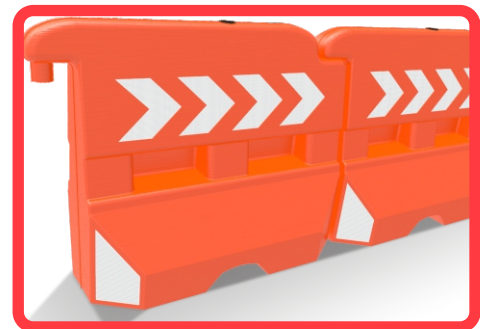

Measures are nominal and can vary, between +/- 2%.

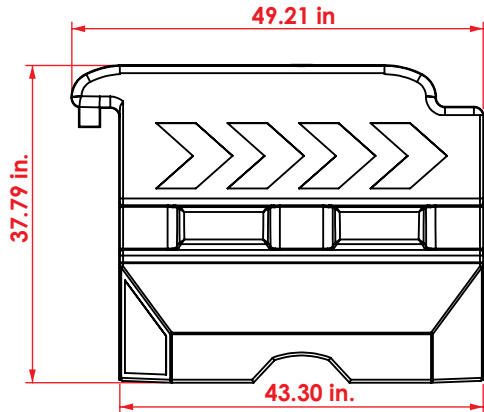

**FRONT VIEW**

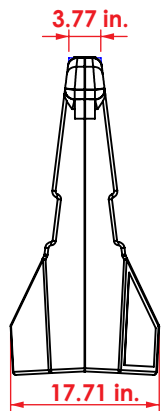

**LATERAL VIEW**

## Measure

<b>Total</b>	Length: 4 ft 1.21 in.
	Height: 3 ft 1.79 in.
	Width: 2 ft 1.98 in.
<b>Reflective:</b>	Optional
<b>Reflective color:</b>	White

