

Volumes, dimensions, and other measures are nominal and may vary by approximately 2%.

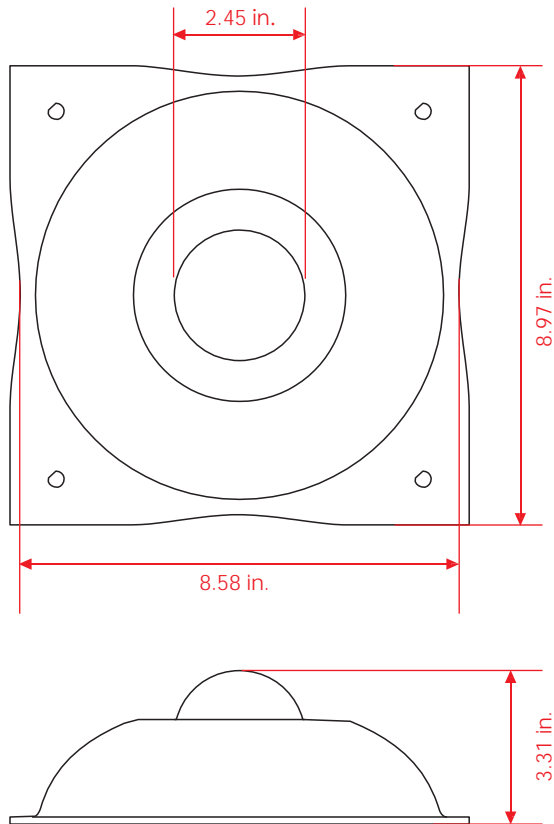

Measures

Material:	Steel.
Measures:	Length: 8.97 in. Height: 3.31 in.
Approx. weight:	5.41 lb.



The surface needs to be dry and clean.
Mark the distribution of every pavement marker.

Two installation methods:

- **Asphalt:** Mark the four boreholes. Place the stainless-steel pavement marker on the place assigned. Then start pounding. You can apply epoxy glue on the base (optional). Make sure not to mistreat the pavement marker by pounding the four 1/4 x 3" nails.
- **Concrete:** Mark the boreholes on the concrete with a 3/16" drill bit to a depth of 3". Insert the four 1/4 x 3" nails and pound them.

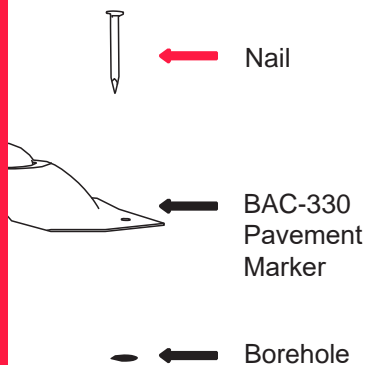

EPOXY GLUE PREPARATION:

1. Mix equal amounts of the "a" and "b" formulas.
2. Stir until the formulas are well combined.
3. Since you can only use it once, get rid of the remaining epoxy glue once the job is finished.