

**i Great savings in storage and transport !**

## UNITY IS STRENGTH

Barrier for multi-functional protection.

This innovative road safety device is unique on market, ideal for an ample variety of uses, including demarcation, signage and cordon off events, providing greater safety and reducing transportation and storage costs.

Suitable to block paths, sign works, manage changes, separate lanes, detours and guide transit.

Perfect to delimit sport activities and special events. With these traffic protection barriers you can have an efficient, safe and affordable solution to any signage and delineation need in public spaces and events.



### Features

- Easy to transport and store. **Nestable** feature help to occupy less space.
- Barrier can adjust in different configurations and lengths, according to the specific needs of the project or event.
- Barrier with modular system to assembly easily, exclusive on the market.
- Can be used empty or with two sand bags of 22 lbs each bag.
- Manufactured in HDPE in orange color, with UV protection to provide a long life span, resistant to inclemency and temperature changes.
- Option to add reflective sheeting in white or amber color to increase night visibility.
- Saves up to 75% in storage and transportation costs.
- Fast and safe installation with the male-female assembly system that allow to reach the desired length, depending on project needs, one person can assembly with a minimum effort.
- Ideal to guide people to safe places.
- These features make of nestable road barriers, the efficient and convenient option for management and control of transit.



**WATER FILLING**  
(maximum of 7.8 in)



**2 SAND BAGS OF 22 LBS EACH (OPTIONAL)**



**SAFE COUPLING**



**STORE UP TO 99 PCS PER PALLET**

Dimensions and other measures are nominal and may vary by +/- 2%.

Dimensions in: in

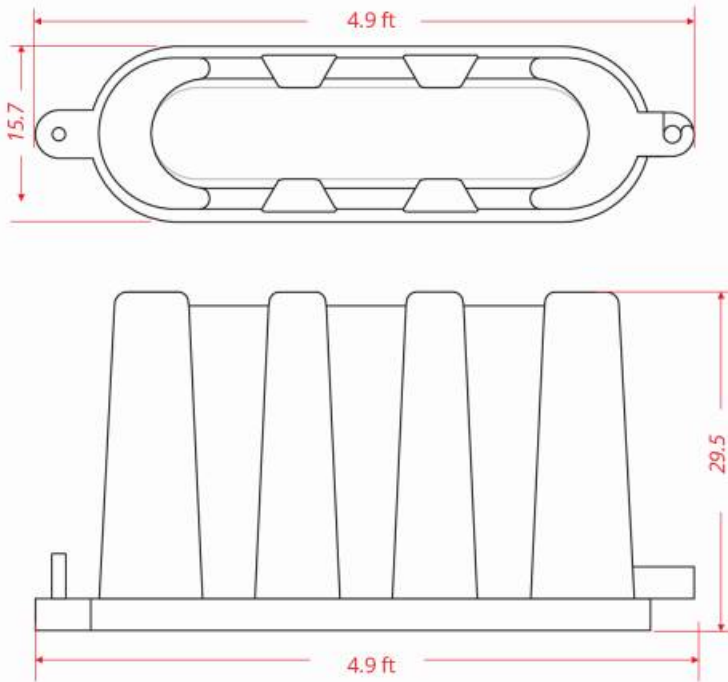

## Measures

<b>Total</b>	Total Length: 4.9 ft Width: 15.7 in Height: 29.5 in
<b>Color of Reflective Sheeting:</b>	White or amber
<b>Approx. Weight:</b>	18.739 lbs.
<b>Weight (w/filling):</b>	62.831 lbs.



Dry box of 53" with approx. 1,300 nestable barriers. Channelize up to 6397 linear feet.

