

Leader don't follow steps
... marks the way



What is a Tubular Barrier?

Safety barrier -one in its kind- that can carry wheels thanks to its good design. Easy to handle with manual grip.

The main use is to cordoning of forbidden zones. Useful as a traffic safety limiter.

Its suggested use is forming lines, triangles, quadrangular and circled areas.

Thanks to its features is one of our Premium Exportation Products.

FEATURES

The **Tubular Barrier** works to conduce crowds of people to a specific place.

- Two turning pods to facilitate stacking and transport.
- Line colors: orange and black, more variety on demand.
- As a high weight molecular polyethylene product, the uniformity in wall's width means better performance in any condition.
- Lightweight but with firm pods that can be solid or hollow.
- Extendend life of service due its durable material all weather resistant.
- UV ray protected item.
- The barriers are stackables for easy transport.
- Link system male-female to make straight rows or curves.
- The crimp between pieces is easy, just one person can do without effort.
- As an additional option, barrier can carry reflectives for better nightly visibility.
- This barrier integrates an special frame for your warning message or your corporative logo.
- With the option to carry wheel spinners (3") or firm pods according your design. Pods are fillable with sand or water (not included).



Measures are nominal and can vary, between +/- 2%.

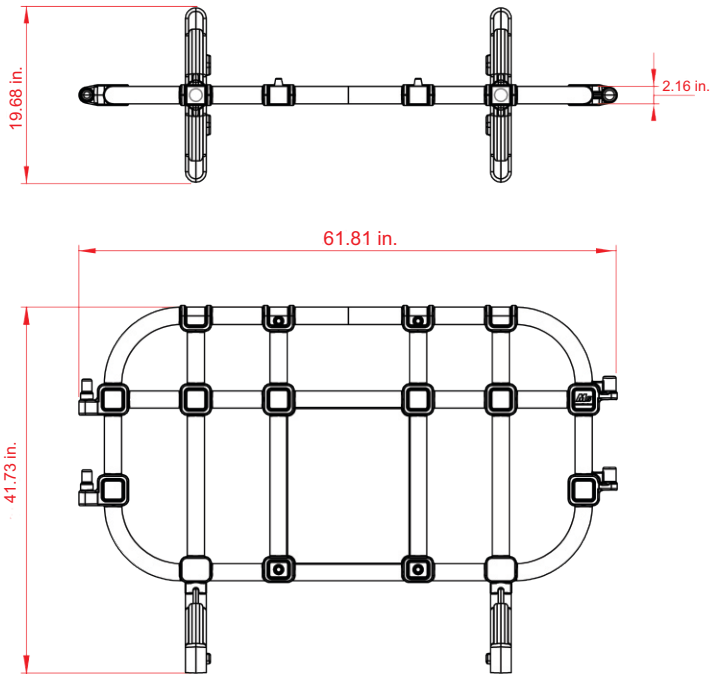

Measure

Total	Length: 5 ft 1.81 in. Height: 3 ft 5.73 in. Width: 1 ft 7.68 in
Reflectives:	Optional
Reflective color:	White
Reflective area:	12.99 x 15.74 in.

