



A leader doesn't follow  
... marks the way

## THE PERFECT DUO?

The union of these two devices generates a correct and safer traffic flow, due height calls the attention of motorist.

These elements are perfect to guide transit in different situations, including construction zones, temporary detours, and are also part of signage in emergency or service vehicles.

This innovative device not only ensures a high visibility and durability, but ease a simple and adaptable installation to different signage needs.

Useful for commercial and service zones, such as gas stations, drug stores, parking lots, supermarkets, etc.

## Features

### Barricade:

- Body manufactured in MDPE with UV protection in orange color to be highly visible.
- One of the main features is its base, perfect to fill with sand, providing greater stability; it can be oval or deco type; in yellow color.
- Incorporates two or four reflective stripes (option to be in both faces), these ensure the perceptibility, above all in periods of reduced luminosity such as night or under fog.
- Resistant to shocks and impacts.

### Arrow

- Arrow shaped with rounded borders to avoid damages; reflective face in yellow or white color.
- Body in a single piece manufactured in MDPE, red or black color.
- Option to be in right or left direction.
- Flashing mode, with ability to synchronize to other devices.

### Lighting System

- 300 mm x 60 mm solar cell.
- 21 ultrabright LEDs with conical optics with mirror that expand light.
- Powered by two AA rechargeable batteries.
- Incorporated JVM circuit to synchronize with other arrows.
- 656 ft of effective visibility.
- IP68 protection level.



Dimensions and other measures are nominal and may vary by +/- 2%.

Dimensions in: in

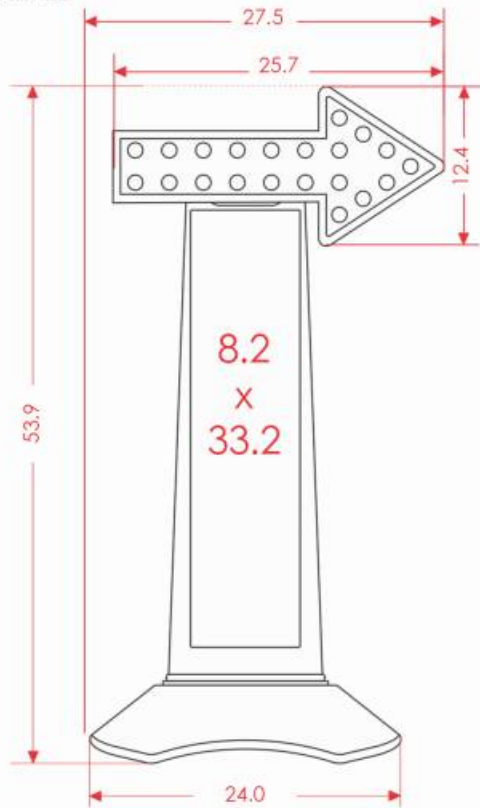

## Measurements

### General Measures

Length: 27.5 in  
Width: 15.7 in  
Total Height: 53.9 in

### AD area

Length: 8.2 in  
Height: 33.2 in

### Reflective Sheeting:

From 2 to 4 stripes per side

### Color of Ref. Sheeting:

White; preferably

### Approx Weight:

19.841 lbs

