

Leader don't follow steps
... marks the way

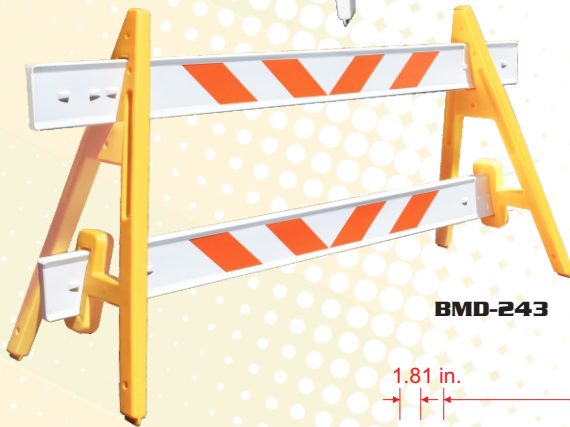

FEATURES

- Consist in one or two barriers fixed in two A-frame support.
- Excellent as a preventive barrier, to stop vehicles, to mark detours and very useful on any road or construction works.
- High resistant to vehicle impacts and any kind shocks.
- Great maneuverability, because its lightweight are replacing the metallic ones use everywhere.
- Easy transport due its lightweight and its modular design.
- High resistance to weathering and durability.
- UV protected means a guarantee of less attrition.
- No sharpen edges and rounded ends to get a harmless product in case of impact.

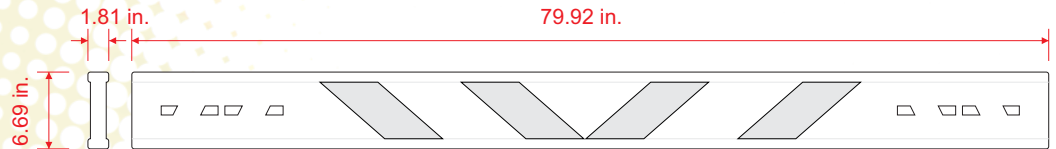

Technical Data:

- * **Made out in:** A-frame supports: (high density polyethylene)
Barriers (PVC)
- * **Reflectives type:** Engineering Grade.
- * **Measure (barrier):** Length: 79,92 in., Height: 6.69 in., Width: 1.81 in.
- * **Base:** Height: 42,32 in., Width: 1.96 in., Length: 28.34 in.
- * **Weight:**

Double: 20,68 lb.
Simple: 15,06 lb.

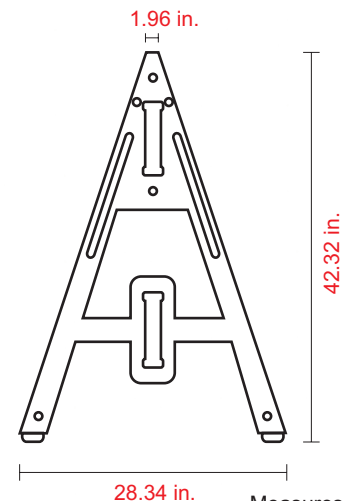

Measures are nominal and can vary, between +- 2%.