

Leader don't follow steps
... marks the way

WHAT ARE BOLLARDS?

High resistant and protective adornment. are align indicators.

Used as protection on sidewalks for divide room between pedestrian and drivers, and to dissuade them to pass thru.

Suggested use mainly in rows avoiding vehicle drivers to park on sidewalks and to not surpass the marker.



Images are merely illustrative models.

FEATURES

- Modern and robust body bollard combines design and safety.
- Help to create a safer and high standard environment.
- (Optional) Cement filled body.
- Made out in medium density polyethylene.
- With reinforced steel skeleton of tubular steel for a better shock resistance well anchored on floor.
- No maintenance needed or minimum.
- Easy to handle.
- Moisture, liquids, and solvents resistant.
- Also bear heavy temperature changes.
- Colors: sand, black, gray and granite (more colors on demand).
- UV resistant.
- Long life durability.
- Very useful in bus stations, airports, shopping malls and as an auxiliary to control traffic.
- Easy installation drowning on cement below floor (see directions).



Measures are nominal and can vary, between +- 2%.

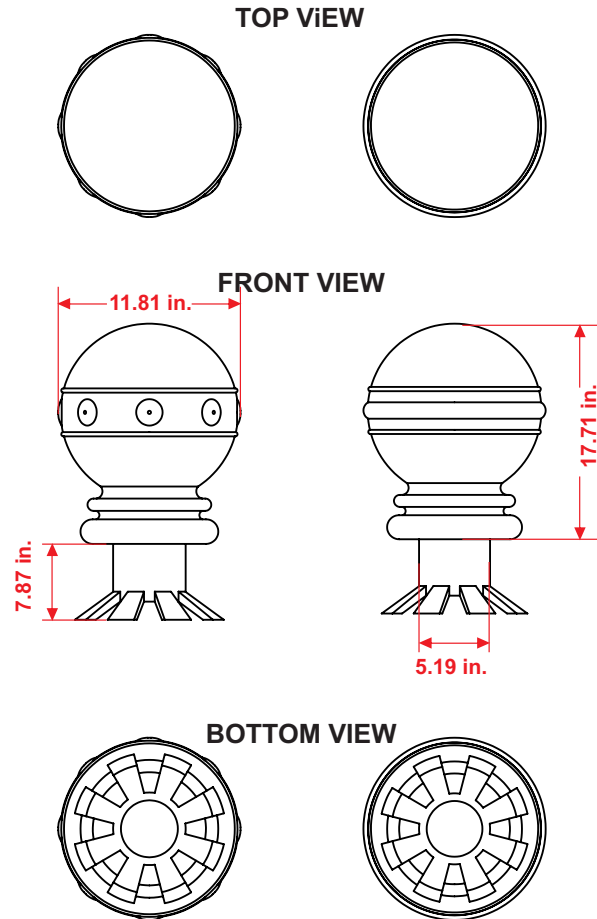

Measure

Total

Functional height: 17.71 in.
Width: Ø 11.81 in.

installation procedure

First mark the auger location, then perforate a hole 10 inches diameter and 9 inches depth with a perforating punch. Clear of dirt the hole as possible and pour the cement mix (previously prepared). Insert just the bollard base, check the level (no more, no less) and fill the rest of the hole to get a good cementation.

