

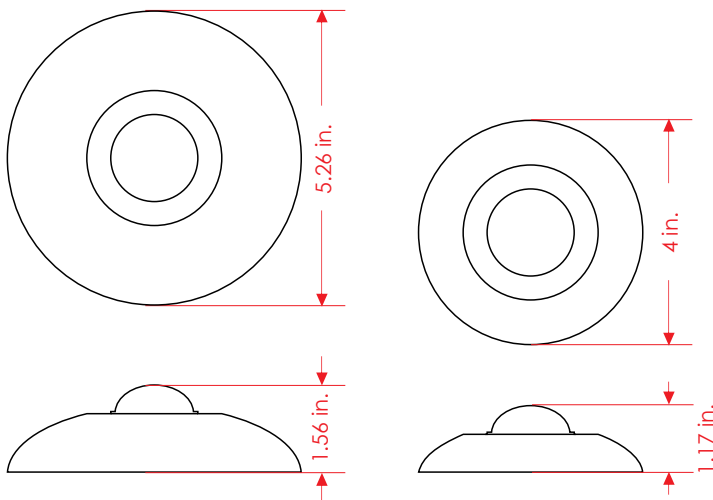

BACI-ES-135-SOLAR



BACI-ES-100-SOLAR



Features

- This Solar Road Stud is perfect for boosting road visibility in low light conditions.
- Highly visible under any weather conditions.
- It's perfect for signaling or guiding a route, areas of fog, freeways, low light areas, parks, etc., or for decorating public squares.
- Highly resistant to friction, abrasion, hits, and bumps.
- Lightweight and smooth body without edges.
- It's perfect as a speed bump or as a vibrating pavement marker.
- The body is stainless steel with high gloss polishing.
- Optional bolt.
- An auto-rechargeable solar power system of photovoltaic cells with a light-sensitive on/off switch.
- The lighting consists of one or two high-intensity red, amber, or white flashing LEDs (BACI-ES-135 or BACI-ES-100).
- The transparent crystal sphere works as a light diffuser.

Technical specifications

Material:	Stainless steel.
Mini solar panel:	Silicon.
General measures:	
BACI-ES-135-SOLAR	Ø 5.26 in. x 1.56 in. height
BACI-ES-100-SOLAR	Ø 4 in x 1.17 in. height
LEDs' wear-out life:	100,000 h.
Luminous intensity of each LED:	More than 5,200 millicandelas.
Flashing light sequence:	1 flash per second.
Distance of LED visibility:	218 yd
Power efficiency:	36 h. working with 7 h. charging in direct sunlight.

Smart on/off switch.