

A leader doesn't follow steps, **he marks the way.**

WHAT'S AN ALUMINUM PAVEMENT MARKER?

It's a road traffic control device made of aluminum with a reflective element on one or two sides.

WHAT DOES AN ALUMINUM PAVEMENT MARKER DO?

It works as a speed hump and is especially suitable in low visibility areas in the city or on highways at night, in rainy weather, or with fog.

USES

Perfect as a lane separator or speed hump in schools, pedestrian zones, and parking lots.

Features

- Useful to forecast and channel vehicles to other safety areas or the vicinities of dangerous zones like bridges, tunnels, slopes, or curves.
- High strength to impacts and friction from the tires of vehicles and trucks.
- It has abrasion resistance.
- The body doesn't deform and it's molded with aluminum in one piece.
- It has one or two areas to add reflective.
- Easy to install on any kind of road surface (asphalt or concrete).
- The side gaps facilitate its manual placement.
- It includes a bolt for better grip on the floor.
- It has the perfect height (0.78 in.) because it doesn't alter vehicle traffic.
- One or two reflective faces; this will depend if you want a directional or bidirectional vision.
- Natural color.
- The areas for the reflective are specifically designed for the car lights to reflect like a light beam through the driver's eyes.



Volumes, dimensions, and other measures are nominal and may vary by approximately 2 %.

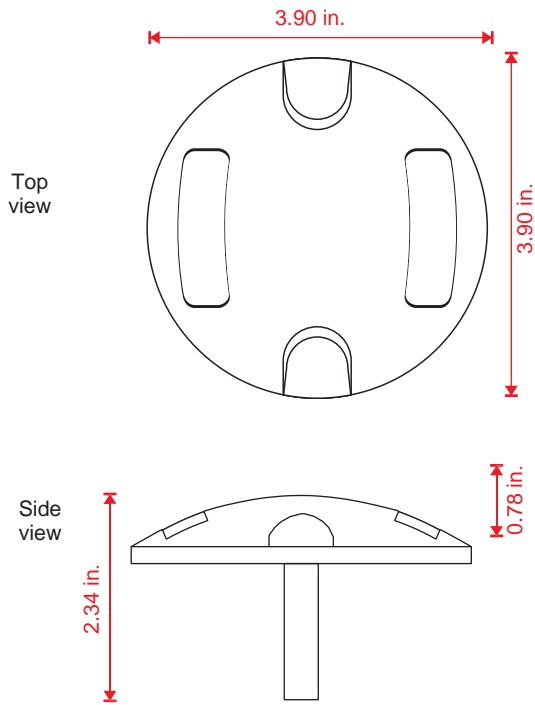

Measures

Total	Diameter: 3.90 in. Height: 0.78 in.
Reflective:	2.56 sq in. per side.
Reflective color:	Amber or white.
Weight:	5.07 oz.

Installation.

The installation is done by hand, usually with epoxy glue.

- 1.- The surface needs to be dry and clean.
Mark the pavement marker distribution (we recommend every 10 in. in staggered formation).
- 2.- Apply epoxy glue on the back of the pavement marker.
Make sure it's completely covered, especially the corners (approx. 3.5 oz).
- 3.- Put the pavement marker and press it.
It doesn't matter if the glue pours out.
- 5.- Let it dry for approximately 2 h.

Make sure that the reflective view is facing the driver's view.

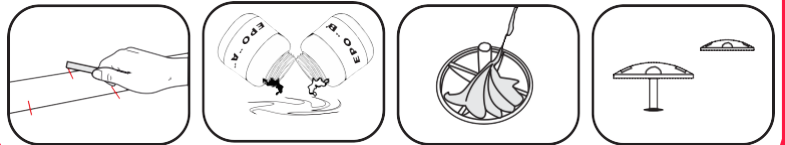

NOTE: EPOXY GLUE PREPARATION

MIX EQUAL AMOUNTS OF THE "A" AND "B" FORMULAS.

STIR UNTIL THE FORMULAS ARE WELL COMBINED.

SINCE YOU CAN ONLY USE IT ONCE, GET RID OF THE REMAINING EPOXY GLUE ONCE THE JOB IS FINISHED.