

A leader doesn't follow,
marks the way...



WHAT A MULTIVIEW BUOY IS?

- Designed to delineate and channelize transit of vehicles; it offers low friction to tires.
- Great visibility during day and night due inner body of tempered glass.
- Non deformable body before shocks and impacts.
- Avant-garde design that makes a road element very visible.
- Manufactured for heavy-duty traffic.
- Adaptable to any even pavement.
- Easy installation (4 nails).
- Made of ABS, it offers better performance of resistance and stretching of materials, even in extreme temperatures with UV protection.
- Body in yellow color (other color upon request).
- 2 laterals that protect sphere, avoiding direct shocks.
- Sphere has sandblasting border, helping to avoid skids on tire.
- Option to be solar, increasing considerably the visibility, above all, during night.

Features

	Buoy
* Bump manufactured in:	ABS.
* Inner body in:	Tempered glass of high resistance
* Measures:	Length: 7.5 in x 7.5 in. Height: 2.8 in.
* Color of buoy:	Yellow.
* Compressive strength (load):	26,000 kg/cm ² .
	Sphere
* Made of:	Silicon glass, with thermal type tempered and sandblasting finish.
* Measures:	Diameter 57 mm. Height: 28 mm.
* Color of presentation.	Natural.
* Density:	2 500 kg/m ³ .
* Softening Point:	730 °C approx.
* Thermal conductivity:	1.05 W/mk.
* Hardness:	6 or 7 Mohs scale.
* Poisson's coefficient:	Vary between 0.22 & 0.23.
* Compressive Strength:	Greater than 10,000 kg/cm ² .
* Working modulus:	500 kg/cm ² .
* Modulus of rupture:	850 kg/cm ² .
* Tensile Strength:	300 & 700 k/cm ² .



Dimensions and other measures are nominal and may vary by +/- 2%.

Measures

Total	Length: 7.5 in
	Width: 7.0 in
	Height: 2.8 in
Reflective material:	1 sphere

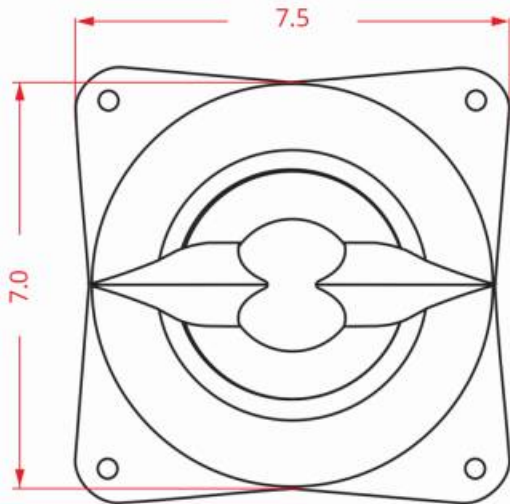

FRONT VIEW

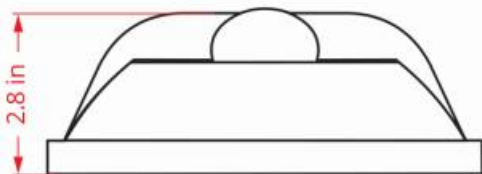

TOP VIEW



Installation

1. Prepare the surface (must be clean and dry).
2. Mark the distribution of every buoy.
3. Place the buoy and nail the spike nails one by one.

- In case of only using epoxy resin:
 1. Apply the epoxy resin on the lower part of the buoy, and make sure of covering the corners.
 2. Then, place it on the desired position and pressure the buoy (it doesn't matter if you spill glue).

Note: For better fastening, it is suggested to use both, epoxy resin and nails.

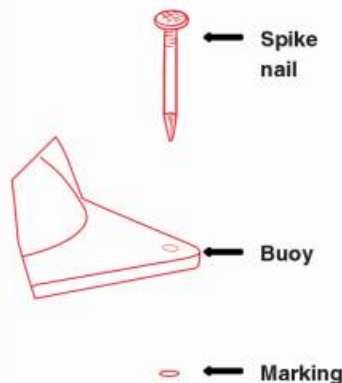

EPOXY RESIN PREPARATION

1. Compound equal amounts of "a" + "b" substances.
2. Stir until a homogeneous mixture is obtained.
3. Once you are done, dispose of the epoxy resin residuals (it is for single-use only).