

Leader don't follow steps
... marks the way

WHAT IS THE BUOY I-55?

Horizontal signalling device used in roadways, highways and city streets mainly as a speed reducer, bumps or zone limit marker.

Buoys optimize road traffic promoting a more safe and secure mobility for light or heavy vehicles, non-motorized and pedestrians too.

Useful for channelize traffic flow giving safety and security on vicinities of schools, hospitals and else.

Also warns about upcoming events on the way, like bridges, tunnels, slopes, curves or deviations.

Buoys are useful as a lane distributors too.



Images are merely illustrative models.

FEATURES

- Designed for mark limits and channelize vehicles.
- Offers a low friction gradient for wheels.
- Indeflexible against shocks, run-ins and other impacts.
- Buoys are functional avant-garde traffic elements.
- Idoneus for create pedestrians safety islands, bicycle protected special lanes, junctions and else.
- Great visibility, widely substitution of floor painting.
- Has high intensity reflective on both faces.
- Specially manufactured for heavy traffic.
- No sharpen edges and corners, just a rounded harmless product.
- Adaptive to any pavement, cement or dirt floor.
- Easy installation with 4 nails (included).
- Asphalt: 4 nails 1/4 x 3" just hammer it.
- Cement or concrete: Make a guide with a 3/16" drill bit 3" depth to facilitate nails insertion hammering (optional reinforcement with epoxic glue.

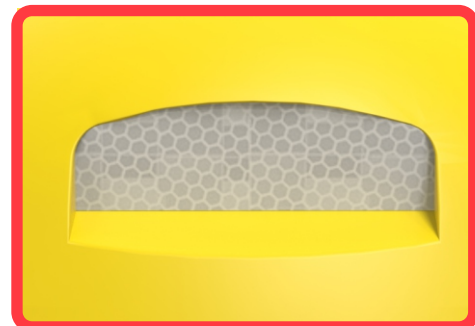
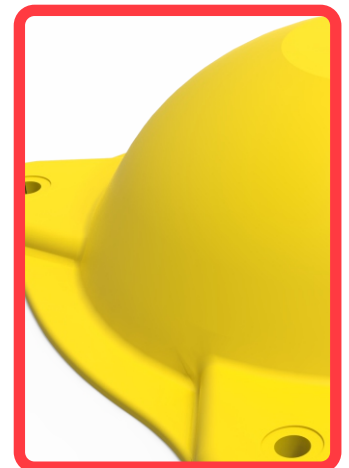

Measures are nominal and can vary, between +- 2%

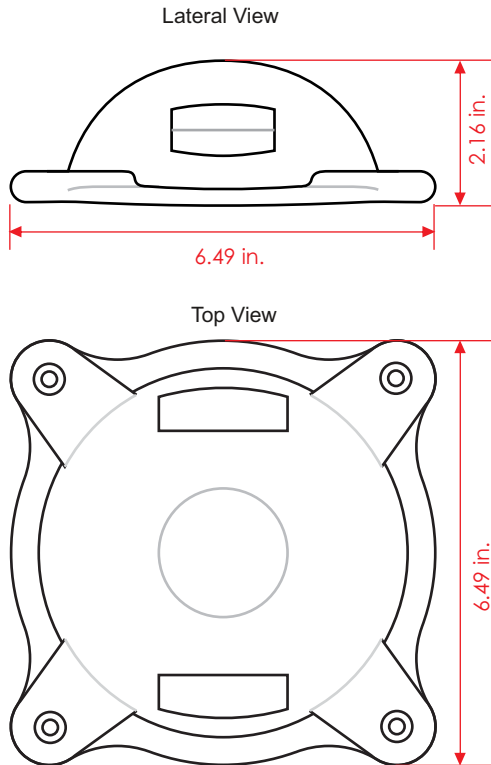

Measure

Manufactured out in:	High density polyethylene
Dimensions:	Length: 6.49 in. x 6.49 in. Height: 2.16 in.
Weight:	10,33 oz.
Color:	Yellow or green.
Reflective area (each face):	1.16 sqr in.
Effective contact surface:	42.16 sqr in.



installation procedure

- Prepare the surface where the buoy is gonna be installed, must be clean and dry. Mark the holes on floor for each buoy.
- **On asphalt roads:** Mark four augers, put the buoy in its place, just nailed. (Optional) Apply epoxic glue on device reverse bottom for best fixation. Hammer carefully 4 nails 1/4" x 3".
- **On cement roads:** Make a guide with a 3/16" drill bit for easy hammering insertion of 4 nails 1/4" x 3". Apply glue on device button and press it on floor, just as an optional reinforce.

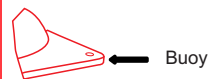
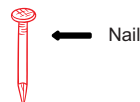

DIRECTIONS TO PREPARE EPOXIC RESINE

- Take similar quantities of both components "a" + "b".
- Stir enough until get an homogeneous mix.
- Two hours aprox. for drying.
- After installation, castaway the leftovers of epoxic resine, is for one use only.