



Leader don't follow steps
... marks the way



Features

- Designed to mark and channelize traffic.
- Ideal to confine bus rails and protected bicycle tracks elsewhere.
- Collision high resistant, our boomerangs are practically undestroyable.
- Integrated color, no maintenance needed.
- Undeformed against impact or else.
- Special reflectives to be seen from any angle; two in front and three on rear face.
- Manufactured in one piece of solid material.
- No sharpen edges, no metallic parts inside, totally harmless.
- All weather resistant.
- U.V. ray protected, no color changes.
- Adaptive to any kind of floor.
- Easy to install with 4 fixation points.
- Can be combined with a Poliflexy® 66 Bollard (code: ITO-PF-66) for more benefits.

•Optional: Poliflexy® 66 Bollard
(code: ITO-PF-66)



Installation note:

- Asphalt Roads: Steel nails $\varnothing \frac{1}{2}$ " x 10"; hammer carefully.
- Cement roads: Made a guide on road with a drill bit $\frac{1}{2}$ " down to 8" then hammer nails.

Technical Data

Manufactured : Polyethylene.
Measure: Length: 19.68, Height:3.93, Width: 3.93 in.
Weight aprox: 213,58 oz.
Color: integrated yellow.

Measures are nominal
and can vary,
between +- 2%.

TOP VIEW

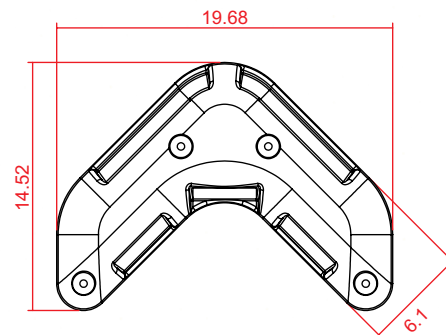

REAR VIEW

