

A leader doesn't follow steps
... he marks the way

Features

This traffic delineator, commonly used as a multipurpose safety element, is ideal to demarcate streets.

- It's useful in highways, avenues, roads, routes, circuits, parking lots or to restrict areas.
- It is also used to create temporary roundabouts and guiding traffic.
- It can withstand hits and crashes of vehicles without accidents and it's totally harmless for pedestrians.
- Made of linear polyethylene with UV protection.
- It's highly resistant to the environment and extreme temperature changes.
- Its heavy octagonal base provides stability and more tolerance to the wind.
- It has three high quality reflective rings that give excellent visibility at night.
- It has another reflective on top that emits light to drivers and you can also put a plastic chain or a **Barricade Tape**.

(Code: CIN-PRE and CIN-PEL).

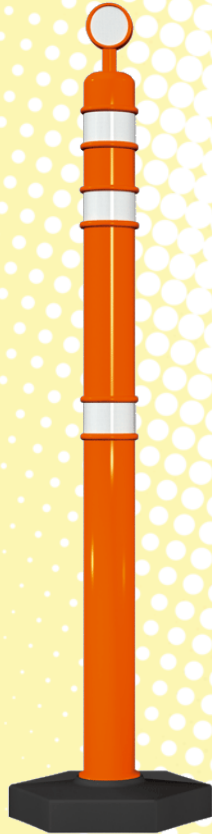

Technical specifications:

- * **Made of:** Linear polyethylene
- * **Color of the post:** Orange
- * **Post measurements: Total Height:** 62.20 in. **Total length:** 15.74 in.
- * **Base material:** Linear polyethylene
- * **Base measure: Width:** 7.87 in. **Height:** 3.74 in.
- * **Base width:** 7.87 in. per side
- * **Base weight with sand:** 8.157 lb.
- * **Color of the base:** Black
- * **Reflective (optional):** 3 white rings
with a diameter of 1.96 in. and a \varnothing of 3.14 in.
- * **Total weight:** 10.76 lb.

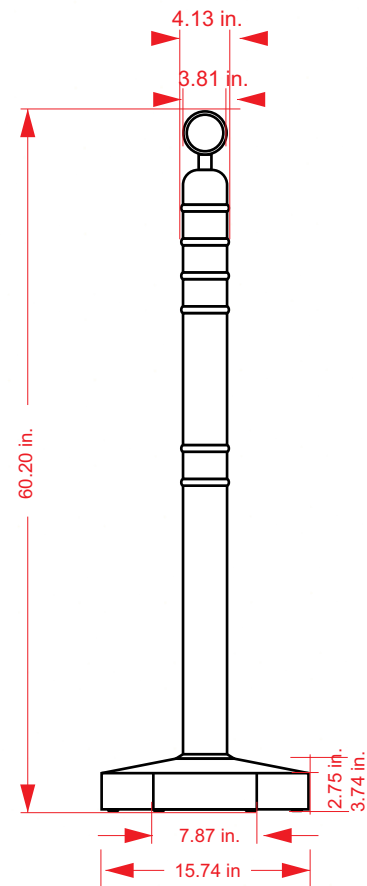

Volumes, dimensions and other measures are nominal and may vary approximately 2 %.