

**A leader doesn't follow,  
marks the road...**

**What's a double planter?**



Modular system that can be applied in any building or house.

Thanks to its storage capacity and water reabsorption that saves time of caring to grow vegetables, as maintain fresh plants without the necessity of water for indefinite period.

Ideal for any outdoor or indoor space where is desired to place a plant. It is commonly used in plazas, roof top, gardens, homes, offices, et al.

Customization: According to your needs, this can be label with the name of the material made of or with the institutional logo.

## Features

- Manufactured in one piece of medium density polyethylene.
- It doesn't has riveted parts, preventing tensile strength point or fragility that can affect to its resistance and can be reflected on its usage.
- Resistant to climate conditions.
- UV protection.
- Double wall for water reserve.
- 7 holes for a water re-absorption.
- Drainage plug.
- It doesn't require special installation for its placement.

**More green areas means more help to win the fight  
against Global Warming**

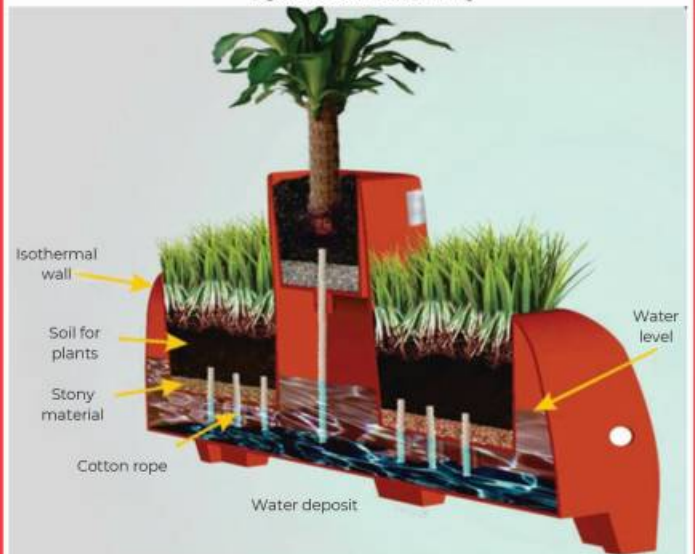

Dimensions and other measures are nominal and may vary by 2 %.

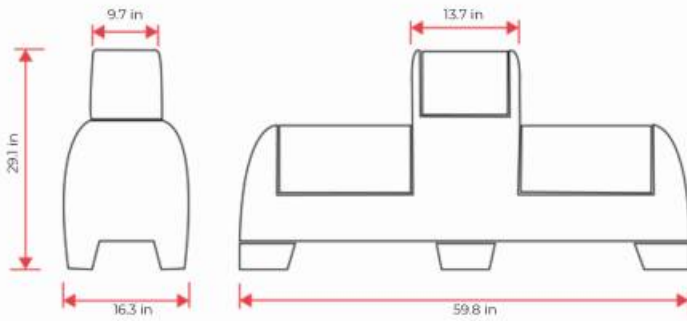

## Measures

- **Measure of piece:** Length: 59.8 in.  
Width: 16.3 in.  
Height: 29.1 in.
- **Manufactured in:** Manufactured in polymer of high resistance.
- **Water storage:** 1.5 gal.
- **Color:** Chocolate.

