

WHAT IS A TACTILE PAVING FOR BLINDS?

Tactile paving in floors favours blind and visual disabled persons mobility.

There are two different tile relief textures recognizable for those impaired.

Podotactile guide tile: works to create a safety way.

Warning podotactile tile: works as a warning message, for put in alert, make a stop or take caution.

Its use is recommended in hospitals, schools, crossings and any place where is necessary to guide blind people.

FEATURES

- Its main objective is to prevent potential dangers, warn on the knowed risks, and give a trusty guide for blinded people.
- Warn over the basic risks implies in crossing streets, get a bus, to get into a shopping mall, parking lot or climb thru unknowed stairs or ramps.
- Two differen textures guide blind pedestrians:
- **Podotactile guide:** gives direction and advance.
- **Warning tactile-pavement:** indicates a stop warning signal for a potential risk.
- Tactile anti-sliper bezel, Has 0.15 to 0.23 in.
- Manufactured out in PVC.
- Yellow and green are colors often used in other signalisation equipment and contrast with pavement.
- UV ray integrated protection.
- The tile can't create any inconvenience.
- Easy installing on any plane surface just mix the components and follow the procedure.

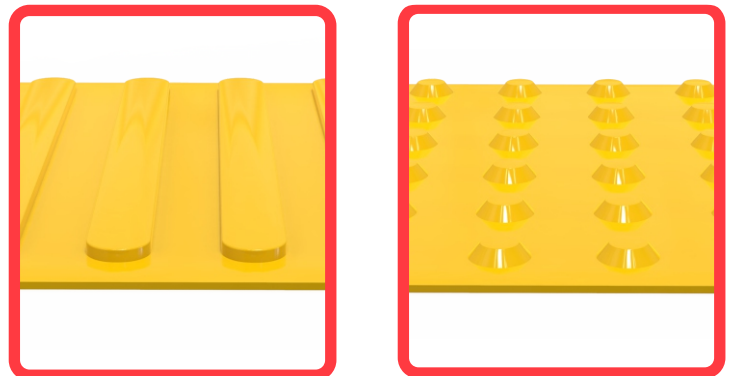

TEXTURE DETAILS

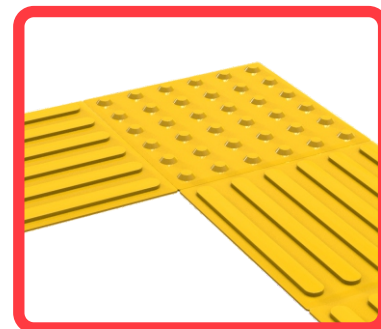

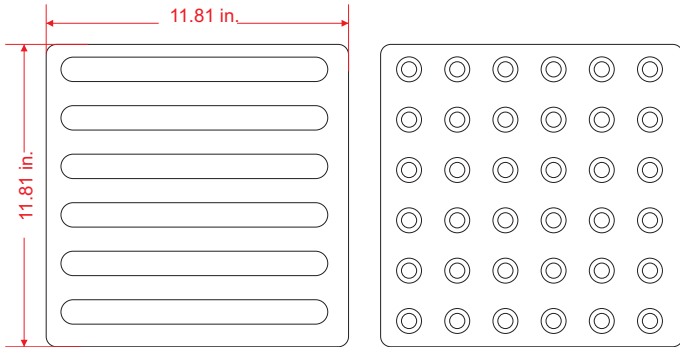

Measure

Total	11.81 x 11.81 in.
Reflective:	None
Body Color:	Yellow, green, gray or black
Weight:	16,93 oz.

END OF THE TACTILE GUIDE

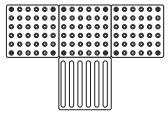

DIRECTION CHANGE AND END

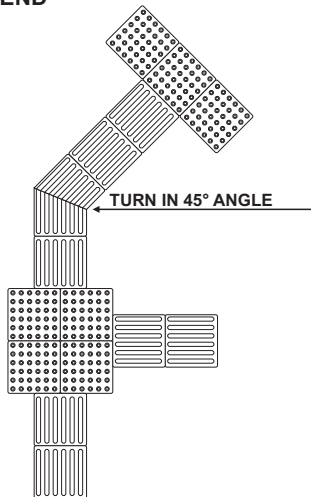

DIRECTION CHANGE

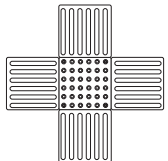

installation procedure

Easy installation.

Verify that planned place for install is clean and free of dust, solvents or dirt.

Prepare the mix of adhesive formula: (33,81 us oz. /1000 ml) of the A component with (3.81 us oz. / 100 ml) of catalyst (B component) and stir well.

Each tile requires about 3 spoons (50 ml) of the adhesive mix to maintain fixed to floor.

Use a 1/2" brush to distribute the mix along the tile reverse. Make a contact test: when the mix feels less sticky on fingers, then is ready. With the tile well cemented put it in the designed place and press lightly.

The adhesive lose its properties in a period of 24 hrs and the glue warranty expires. Castaway leftovers is one use product.

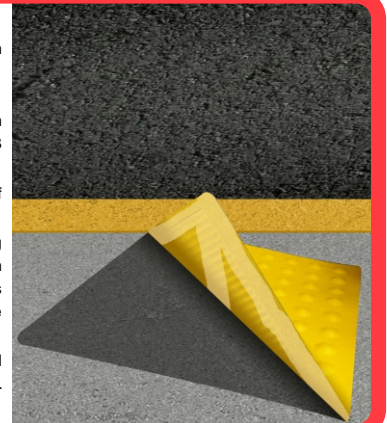

Nota:

Follow the procedure, step by step, to guaranteed the adhesive capacities of the mix and the installation of the tactile guide for visual handicapped.

