

Leader don't follow steps  
... marks the way

Images are merely illustrative models.

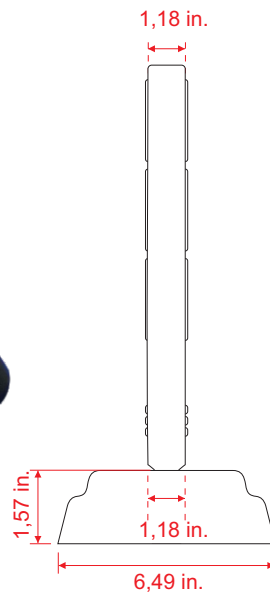
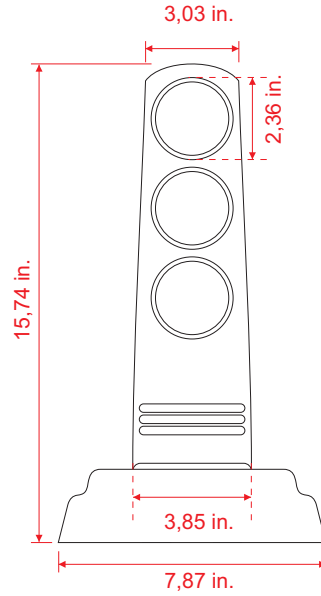
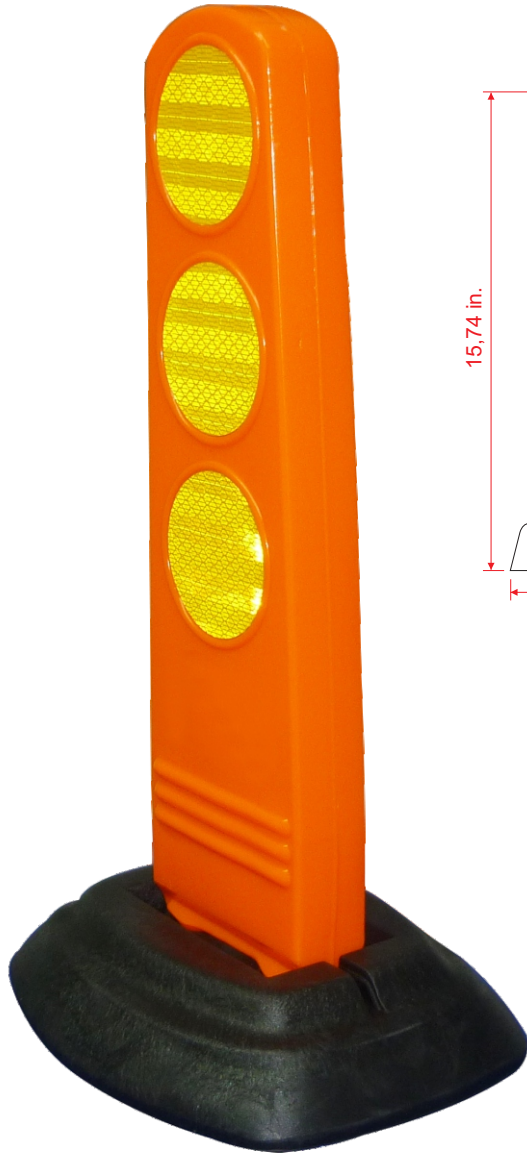

Measures are nominal and can vary between +/- 2%.  
All in inches and pounds.

## FEATURES

- \* **Manufactured out in:** Body in Poliflexy® tongue  
Black base in rigid PVC.
- \* **Measure:** Length: 7,87 in., width: 6,49 in.  
Height: 15,74 in.
- \* **Reflective area:** diameter 3,03 in.
- \* **Line Color:** fluorescent orange and black base.

## WHAT TRAFFIC PALLETS ARE FOR?

- Safety traffic channelizer pallet.
- Body manufactured out in Poliflexy®, our exclusive registered material (sum of flexibility and resistance).
- Support heavy impacts and rebounds to original position.
- Resists snow, rain, heavy sun (has integrated U.V. rays protection), extreme temperature changes and more else.
- It's light-weight helps for very easy transportation.
- As a high technology traffic piece is absolutely harmless to vehicles, persons or fauna: has no metallic parts, no sharp edges and it doesn't rip or fragment.
- Anti-flare angle 25.6°.
- It's recommended to be install in an 8° angle related to incoming traffic flow and the reflective rectangle for a better performance.
- 3 high intensity reflective areas more.
- Idoneus for deviations, merges and crossings.
- Installation does not need any pre-assembling and almost no need any maintenance, saving time and money.
- Easy to put directly on pavement.
- Easy to replace.
- Anchorage with four special large screws and tacketts.

## Anchorage system

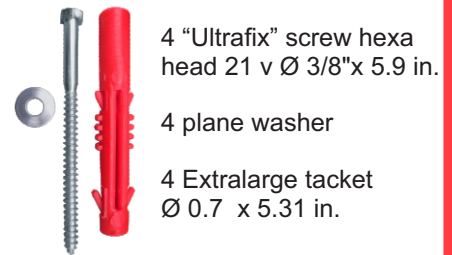

4 "Ultrafix" screw hexa head 21 v Ø 3/8" x 5.9 in.

4 plane washer

4 Extralarge tackett Ø 0.7 x 5.31 in.