

Leader don't follow steps
... marks the way



WHAT IS THE ARROW SAFETY PALLET?

Is a pallet for easy put-&-remove that have two features: it's a light-catcher (with reflective) and also is the cap.

Its main function is to reflect, signalise and guide vehicles out of forbidden zones or work places and also as a safety traffic marker.

Its an addition to put on the top of cones, barriers and barricades to bring a luminic signaling.

FEATURES

- Easy to install, secure attachment.
- The arrow pallet has thread to fix it firmly.

Manufactured out in polypropylene for resistance and durability

UV ray protection integrated

Line colors: Black and white.



Measures are nominal
and can vary,
between +/- 2%

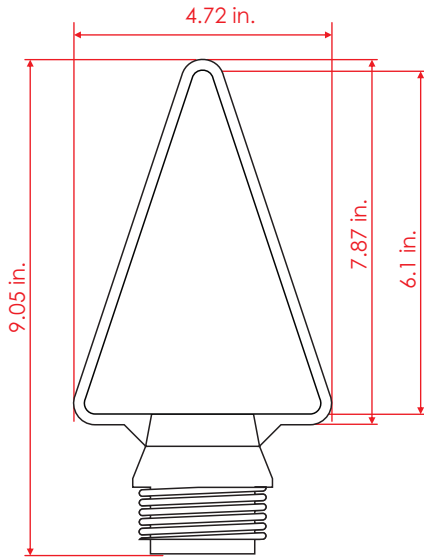

FRONT VIEW

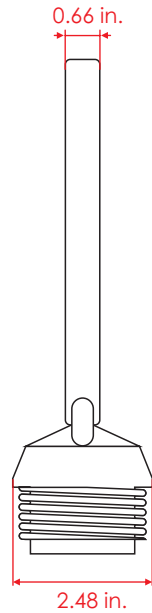

LATERAL VIEW

Measure	
Body:	Length: 4.72 in.
	Width: 0.66 in.
	Functional Height: 7.87 in.
	Total height: 9.05 in.
Reflective color:	Amber or white

