

A leader doesn't follow
...marks the way



PADDLE WITH TWO FACES

Element used to control vehicle and pedestrian transit.

Integrated handling for a versatile manual use, can be set in post or cone.

Ideal to control transit of vehicles, machinery and allow pedestrian passage in zones with public works or events with people and car excess.

Convenient and easy to handle.

Features

- Can include different message in faces, according to project requirements.
- Versatile handle for manual use and can be mounted on post.
- Blow-molded body in a single piece, made of polyethylene in yellow or orange color with great durability.
- UV protection.
- Ergonomic handling for easy maneuverability.
- No maintenance needed.
- Stackable paddle, transforming into an affordable device for transport and storage purposes.



Volumes, dimensions and other measures are nominal and may vary by approximately + / - 2 %.

Dimensions in: in

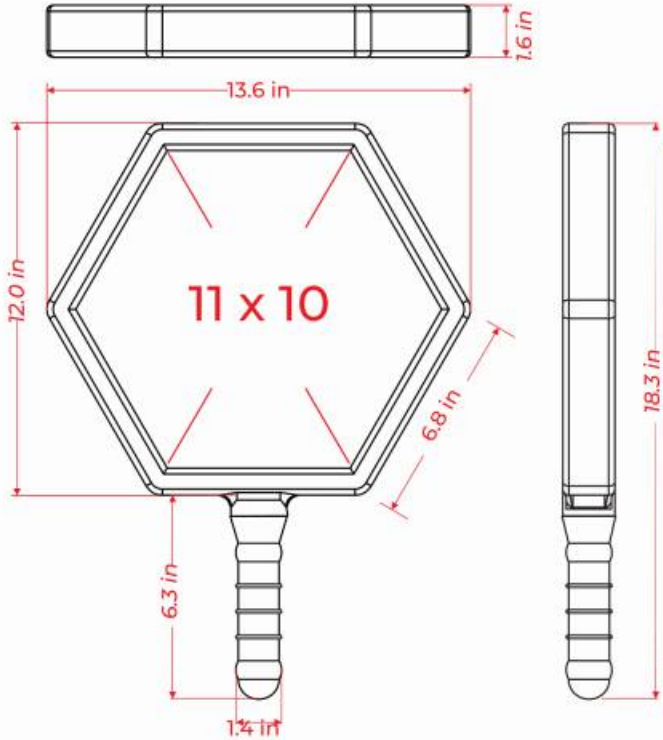

Measurements

General Measurements

Length: 13.6 in

Width: 1.6 in

Total Height: 18.3 in

Reflective Sheeting Color (one/two faces)

According to project

Around Weight

0.771 lbs

