

Patent Pending



A leader doesn't follow
...marks the way

DOUBLE SIDED TRAFFIC PADDLE

Device with hexagonal shape with two views according to the project requirements.

Element used to control transit of vehicles, machinery and allow the passage of pedestrians in zones with public works or event with people and cars excess.

Suitable to mount on post or traffic drum.

Features

- Body manufactured in one single piece of HDPE yellow or orange color with great durability.
- UV protection.
- Different message on both sides.
- Easy to adjust, with a hook/lock (includes screw) that is adaptable to set on delineator post 122 or traffic drum.
- Post has option to add tape, with handle to move the device.
- Heavyweight base manufactured in LDPE in black color, improving stability.
- No maintenance required.
- Useful for the entrance and exits of school, hospital, parking lots and others.
- Ideal for valet parking, guide crowds and others.



Volumes, dimensions and other measures are nominal and may vary by approximately + / - 2 %.

Dimensions in: in

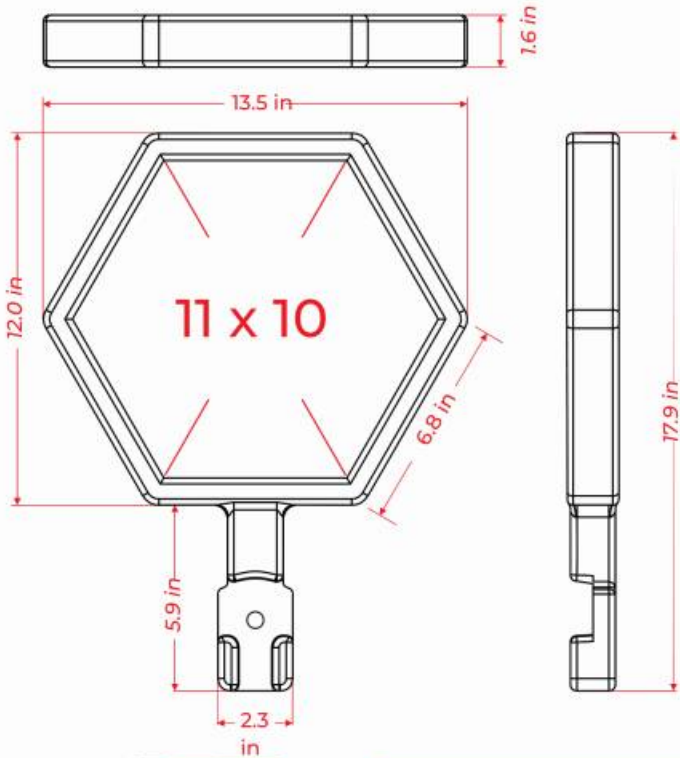

Measurements

General Measurements	Length: 13.5 in
	Width: 1.6 in
	Hexagonal Height: 12.0 in
	Total Height: 17.9 in
Reflective Sheeting	
Color	According to project
(one or two faces)	

