



It complies with NOM-034-SCT2/SEDATU-2022

Technical Features

- Manufactured in black color polyethylene to one side.
- Posteflex® en yellow or grey color.
- Resistance to inclemency and temperature changes, with UV protection.
- Anti-humidity and recyclable; long life span due it doesn't rusts.
- Vandal-proof, thanks to plastic material has zero resale value neither work for other uses, avoiding thefts.
- Stackable. reducing transport and storage costs.
- Easy installation; posteflex® with tubular reinforcement on interior or steel RHS.

Solar Systems

- Solar power supply panel on top part.
- LEDs with conical optics and mirrors causing a better light expansion; in all the sign.
- 1.2 V batteries.
- JVM power supply electronic system that synchronizes flashing of signs at the same time.
- It charges during 6 hours, it lasts 24 hours in flashing mode.

Features

- Signage boards designed according to the 034-SCT2 standard to guarantee visibility and complying the traffic regulations.
- Integrated latest generation LEDs, maximizing visibility.
- Set on Posteflex® that guarantees resistance to adverse climate conditions; includes straps of black polyethylene and screws for a safe fixation.
- Optimal size for an easy recognition at distance of the signs.
- Besides, board can turn to 45° and be a preventive signage.
- 4 extra LEDs on each end to increase visibility.
- Types of signs: Warning: warn about possible risks. Restrictive: indicate prohibitions or transit limitations. Temporary traffic control: inform about works performed in the road. Recreation: sign sites of interest. Service: indicate the available services in the zone. Safety: for emergency situations.
- IP68 waterproof electronic system



Ultrabright LEDs



Solar cell at top part

Dimensions and other measures are nominal and may vary by +/- 2%.

Measures in: in

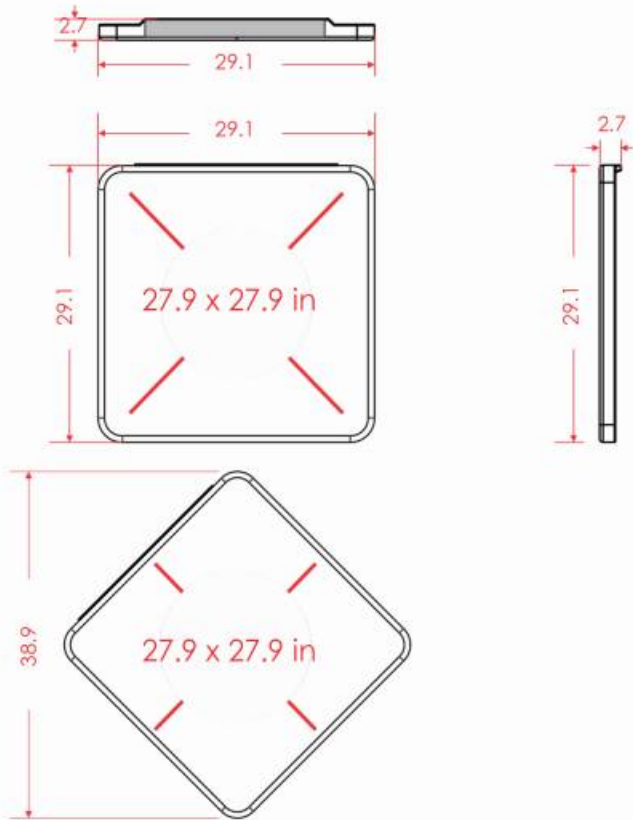

Measures

General Measures	Length: 29.1 in Width: 2.7 in Height: 29.1 in
Vinyl Dimensions:	Length: 27.9 in Height: 27.9 in
Diamond Dimensions:	Length: 38.9 in Height: 38.9 in
Reflective Material:	According with design
Posteflex® Dimensions:	Width: 1.9 x 1.9 in Length: 13.1 ft Thickness: 0.19 in Width: 1.9 x 1.9 in Length: 9.8 in Thickness: 0.11 in

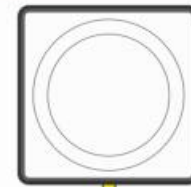

POSTEFLEX®

Height
In urban and rural roads, the lower part of the signs stays at 8.2 ft above sidewalk level.



Modes

