

# ADVERTISING PARKING STOP

## TPES-P-184



### Features

- Advertising parking stop.
- Made for restricted areas, exclusive lanes, etc.
- It's perfect to use in underground parking lots due to its reflective area.
- UV protection.
- The sloped sides avoid water accumulation.
- The advertisement area of 17.55 in. × 2.34 in. with high intensity reflective makes it visible day and night (optional).
- Three holes for its anchorage.
- Easy to install through steel anchors (not included).
- The advertisement area of the parking stop offers you an excellent strategy for a space to publicize your business or store.

### Technical specifications

<b>Made of:</b>	High-density polyethylene.
<b>Weight:</b>	12.58 lb.
<b>Measures:</b>	Length: 6 ft Height: 3.9 in. Width: 5.85 in.
<b>Pressure resistance:</b>	142,200 lb. × in <sup>2</sup> .
<b>Colors:</b>	Yellow or black.

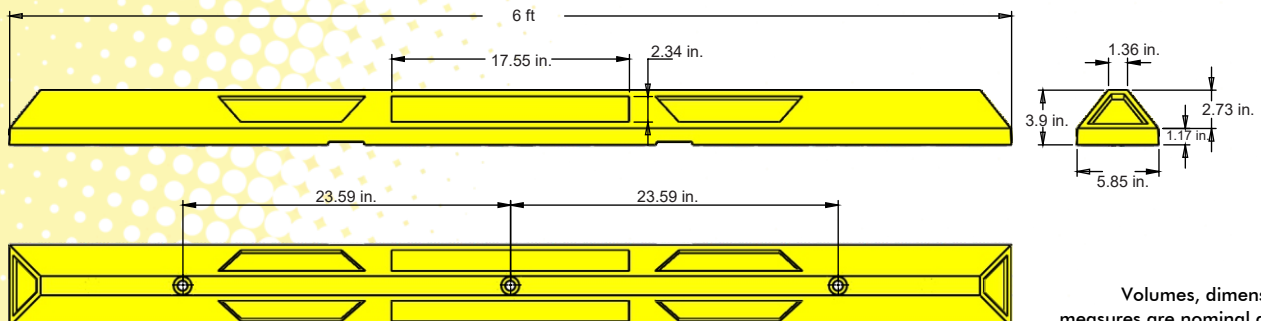

Volumes, dimensions, and other measures are nominal and may vary by approximately 2 %.