

A leader doesn't follow.
marks the way...



TRAFFIC DRUM

Traffic safety device, designed to maximize visibility in highways and work areas.

Manufactured in high quality orange polyethylene, it offers durability and resistance to adverse climate conditions, including the UV ray exposure.

Option to include 4 reflective rings which improve visibility during night, increasing safety. This can be set individually or in group, in work zones, paths closed and can be used to delineate work areas.

Benefits:

This traffic drum is the perfect solution to improve road safety and guarantee protection in work areas.

This comply with NOM-0086-SCT2-2023

Features

- Traffic drum helps to channelize circulation within a vehicle flow, such as parking lots to guide transit and delineate specific zones.
- Manufactured in a single piece with top handle that allow an easy management and movement, making easier its use; it also has boreholes that allow to set outer lamps.
- Stackable device, reducing transport and storage costs.
- Option to include detachable heavy weight base, to improve stability and avoid tilts caused by wind strength.
- Natural rubber and synthetic rubber used to enhance durability, black color.
- Easy to clean and resistant to liquids and solvents.



Rubber base



Reflective rings



Mounted lamp



Grip to handle

Measures are nominal and may vary by $\pm 2\%$.

Dimensions in: in

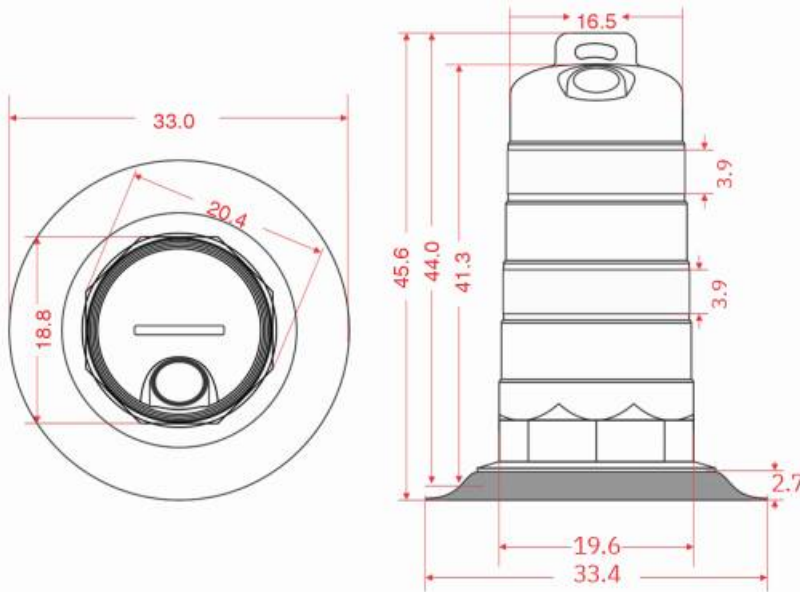

Measures

Traffic Drum Dimensions:	Top Diameter: 16.5 in Lower Diameter: 23.2 in Height: 44.0 in Height with Base: 45.6 in
Around weight of Traffic Drum:	7.716 lbs
Base Dimensions:	Height: 2.7 in Ø 33.4 in
Around Weight of base:	19.621 lbs
Reflective Sheeting:	3.9 in of width in white color (preferably)

