

LUX ROAD STUD

V-LX



Features

- * The modern, attractive, striking, state-of-the-art design makes it stand out under any type of pavement.
- * It's a single piece, lightweight, and doesn't have sharp edges or borders.
- * It has two reflective faces.
- * The reflective surface surpasses the minimum required by the **ASTM standard**.
- * It bears hits, bumps, friction, abrasion, and the elements.
- * The reflectives are high retro-reflection optical prisms that increase their nighttime visibility even in extreme weather.
- * The side indentations facilitate their maneuver and installation.
- * The base design gives it higher adherence with bituminous marker adhesive or epoxy glue; this makes the contact surface surpass the minimum required by the ASTM standard.
- * The reflectives are high retro-reflection optical prisms of MMA.

* PATENT PENDING

Technical specifications

* Measures:	Length: 4.17 in. Width: 4.17 in. Height: 0.78 in.
* Colors:	White, amber and red.
* Weight:	4.2 oz
* Angle of inclination:	25°.
* Body material:	ABS.
* Reflective material:	MMA.
* Reflective surface per side:	3.29 in ² .
* Useful contact surface:	16.64 in ² .
* Pressure resistance:	71,100 lb/in 2mm deformation

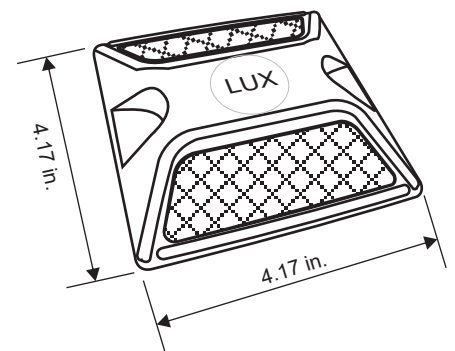

Volumes, dimensions, and other measures are nominal and may vary by approximately 2%.