



- "Ultrafix" screw hexagonal head 21 v Ø 3/8" x 5.9 in.  
 - "Extralarge" tacket Ø 0.7 x 5.31 in./-Plane washer.

## FEATURES:

- High impact resistant due its flexibility.
- The Flex-Post 100 has a unique design.
- Base and body produced out in Poliflexy®, soft material and 100% flexible, absolutely harmless in case of shock.
- Can support a lot of running overs without damage. Body made out in one piece with a cap that seals the interior.
- Line color green, orange, white, or blue (more on demand).
- Black base with three bolts to fix safely to the body.
- Every time is impacted, always turn back its position.
- Easy to place and to replace.
- Lightweight, uses little room and facilitates transport and storing.
- With reflective that helps to keep visibility on night.
- Strong anchorage system with 4 screws and special tacket (non included).

Leader don't follow steps  
 ... marks the way

## WHAT ARE THE FLEX-POST 100?

Flex Posts are versatile aligners for use in the most different situations, from indicate to drivers a dangerous risk factor or to mark a work on-road or to make advertising.

Its main function is avoid vehicles to invade forbidden zones, it delimit and mark the reserved zones

Also are idoneus as safety traffic instruments, to mark deviations, parking lots and even to create pedestrian passages.

Useful in road-works and in restricted zones. Efficient and economic signalise.

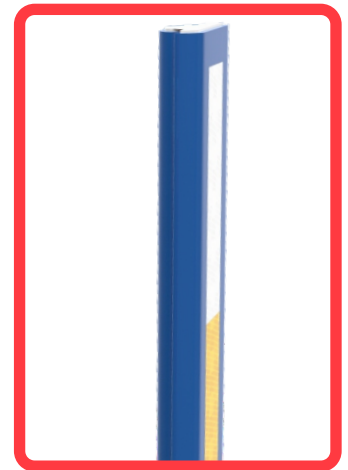

Images are merely illustrative models.



Measures are nominal and can vary, between +/- 2%.  
All in inches and pounds.

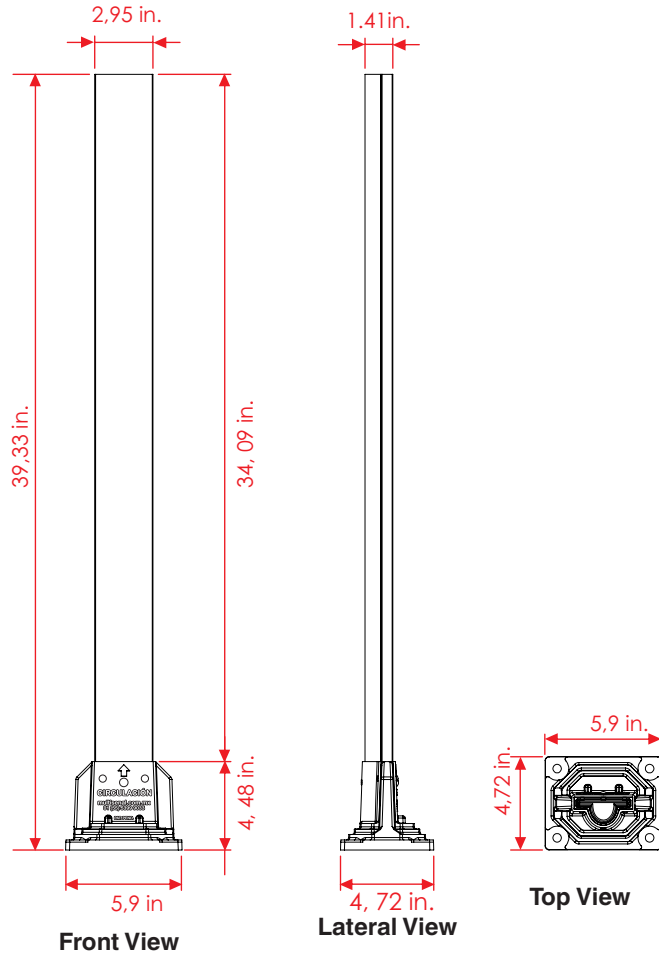

## Measure

<b>Body made out in:</b>	Poliflexy®.
<b>Color:</b>	white, orange, blue or green.
<b>General measure:</b>	base length: 15cm. base width: 12 cm. Height 100 cm,
<b>Weight:</b>	1,23 lb.
<b>Base:</b>	Poliflexy®.
<b>Color:</b>	Black.

PATENTE EN TRAMITE

## Anchorage System

Mark the three holes on ground for place post's base. Then perforate with a 3/4" drill bit down to a 7" depth. Once the holes are correct introduce the tackets and place the **Flex-Post 100**, settle screws with the 3/8" plane washers. Wrist them with a 9/16" nut socket and your traffic post its ready on site.

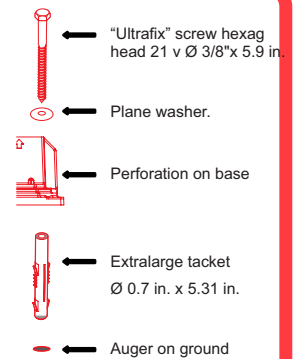

## On cement road

- "Ultrafix" screw hexagonal head 21 v Ø 3/8" x 5.9 in.
- "Extralarge" tacket Ø 0.7 x 5.31 in.